

TABLE OF CONTENTS

WATERFRONT DEVELOPMENT STANDARDS

WD-1	TABLE OF CONTENTS—WATERFRONT DEVELOPMENT
WD-2	GENERAL NOTES
WD-3	REBAR DETAILS
WD-4	SEAWALL CAP AND FILTER FABRIC DETAILS
WD-5	THICKENED SEAWALL CAP DETAIL (SPECIAL USE)
WD-6	EXPANSION JOINT AND LOAD TRANSFER DETAILS
WD-7	CONTRACTION JOINT DETAILS / JOINT LAYOUT
WD-8	ANCHOR/TIE BACK DETAILS
WD-9	ROCK ANCHOR TIE BACK DETAIL
WD-10	EXCAVATION DETAILS
WD-11	10'-0" PRECAST SEAWALL PANEL DETAILS
WD-12	12'-6" PRECAST SEAWALL PANEL DETAILS
WD-13	14'-0" PRECAST SEAWALL PANEL DETAILS
WD-14	16'-0" PRECAST SEAWALL PANEL DETAILS
WD-15	STANDARD DOCKSIDE DREDGING DETAIL
WD-16	STANDARD CONCRETE DOCK AND OUT PILE DETAIL
WD-17	RIP-RAP STABILIZATION DETAIL
WD-18	OUTFALL STABILIZATION DETAIL

CITY OF PUNTA GORDA

326 WEST MARION AVENUE
PUNTA GORDA, FL. 33950
(941) 575-5050

WATERFRONT
DEVELOPMENT
STANDARDS

STANDARD DETAIL

TABLE OF CONTENTS

SHEET NO. WD-1

AUGUST 2019

GENERAL NOTES:

1. CONSTRUCTION SPECIFICATIONS: FLORIDA DEPARTMENT OF TRANSPORTATION "STANDARD SPECIFICATIONS FOR ROAD AND BRIDGE CONSTRUCTION", CURRENT EDITION (FDOT SPECIFICATIONS)
2. DESIGN SPECIFICATIONS: DESIGN SHALL BE IN ACCORDANCE WITH THE FOLLOWING SPECIFICATIONS:
 - A. DESIGN SPECIFICATIONS: AMERICAN ASSOCIATION OF STATE HIGHWAY AND TRANSPORTATION OFFICIALS (AASHTO) LRFD BRIDGE DESIGN SPECIFICATIONS CURRENT EDITION
 - B. DESIGN METHOD: LIMIT STATES DESIGN METHOD (LOAD AND RESISTANCE FACTOR DESIGN).
 - C. U.S. ARMY CORPS OF ENGINEERS ENGINEERING MANUAL EM 1110-2-2504, CURRENT EDITION
 - D. AMERICAN CONCRETE INSTITUTE 318-05
3. MATERIAL STRESSES: ALL ALLOWABLE STRESSES ARE IN ACCORDANCE WITH THE AASHTO SPECIFICATIONS FOR THE MATERIALS SHOWN ON THE PLANS.
 - A. ALL CONCRETE SHALL CONFORM TO SECTION 346 OF FDOT SPECIFICATIONS (EXCLUDING FDOT SPECIFICATION SECTION 346-1 PARAGRAPH TWO.) AND SHALL BE CLASS IV, WITH A MINIMUM 28-DAY COMPRESSIVE STRENGTH OF 5,500 PSI.
 - B. ALL REINFORCEMENT SHOWN IN DETAILS EXCEPT FOR TIE-BACKS SHALL BE LOW-CARBON, CORROSION-RESISTENT CHROMIUM STEEL REBAR, WHICH SHALL MEET THE SPECIFICATIONS AND STANDARD OF ASTM A1035 (LABELED IN DETAILS AS "CHROMX 9100") TIE-BACKS CAN BE EITHER CHROMX 9100 (WHICH NEEDS TO BE ENCASED IN PVC FROM CONCRETE CAP TO DEADMAN) OR EPOXY COATED REBAR. EPOXY COATING SHALL BE "SCOTCHKOTE" BRAND EPOXY COATING RESIN #413 ASTM A775, ASTM A934, AND AASHTO M284.
4. PRECAST SEAWALL PANEL DESIGN CRITERIA:
 - A. THE PRECAST SEAWALL PANEL WAS DESIGNED FOR THE CRITERIA SHOWN IN THE WATERFRONT DEVELOPMENT STANDARDS. SHOULD THE WALL HEIGHT EXCEED THE MAXIMUM VALUE SHOWN IN THESE DETAILS OR IF THE BERM WIDTH IS LESS THAN THAT SHOWN IN THESE DETAILS, AN INDEPENDENT VERIFICATION OF WALL DETAILS WILL BE PERFORMED BY THE CITY.
 - B. NO SURCHARGE LIVE LOAD WAS CONSIDERED IN THE DESIGN OF THE SEAWALL PANEL. NO SURCHARGE SHALL BE APPLIED TO THE BACKSIDE OF THE WALL EITHER DURING CONSTRUCTION OR IN THE FINAL CONDITION. STRUCTURES CONSTRUCTED BEHIND THE BULKHEAD WALL SHALL BE FOUNDED ON SEPARATE DEEP FOUNDATIONS
 - C. THE SEAWALL SYSTEM WAS DESIGNED FOR THE FOLLOWING MINIMUM SOIL VALUES. FIELD VERIFICATION OF THESE VALUES SHOULD BE PERFORMED FOR EACH WALL LOCATION. IF THE CITY'S ENGINEER CONSIDERS THE SOIL TYPES AT A SPECIFIC LOCATION TO BE OF LESSER STRENGTH PROPERTIES THAN THE VALUE SHOWN IN THESE NOTES, AN INDEPENDENT VERIFICATION OF WALL DETAILS WILL NEED TO BE PERFORMED BY THE CITY'S ENGINEER.

SATURATED UNIT WEIGHT = 115 pcf
 MOIST UNIT WEIGHT = 105 pcf
 ANGLE OF INTERNAL FRICTION = 28 DEGREES
 ANGLE OF WALL FRICTION = 21 DEGREES
5. ENVIRONMENT: HIGHLY AGGRESSIVE.
6. SEAWALL PANEL PENETRATION: IT IS EXPECTED THAT HARD MATERIALS MAY BE ENCOUNTERED WITHIN THE EMBANKMENT. THE CONTRACTOR WILL BE REQUIRED TO ACHIEVE THE MINIMUM PENETRATIONS REQUIRED IN THE PLANS, AND IF NECESSARY, USE SPECIAL EQUIPMENT AND/OR METHODS TO FACILITATE THE PENETRATION AT NO ADDITIONAL COST TO THE CITY. THE CONTRACTOR SHALL CONTACT THE CANAL MAINTENANCE DIVISION AS SOON AS HARD MATERIALS ARE ENCOUNTERED.
7. CONSTRUCTION: THE CONTRACTOR SHALL VERIFY LOCATIONS OF ALL UNDERGROUND UTILITIES BEFORE ANY EXCAVATION OR INSTALLATION OF ANY SEAWALL PANEL. ANY DISTURBANCE OR DAMAGE TO EXISTING STRUCTURES, UTILITIES OR OTHER PROPERTY, CAUSED BY THE CONTRACTORS OPERATION, SHALL BE REPAIRED BY THE CONTRACTOR IN A MANNER SATISFACTORY TO THE CITY AT NO ADDITIONAL COST TO THE CITY. THE CONTRACTOR SHALL BE RESPONSIBLE FOR DETERMINING THE APPROPRIATE EQUIPMENT NECESSARY TO INSTALL THE SEAWALL PANEL TO THE PENETRATION DEPTH AS SPECIFIED ON THE PLANS. THE SEAWALL PANEL SHALL BE INSTALLED, A MINIMUM, TO THE TIP ELEVATION(S) SPECIFIED, PRIOR TO COMMENCING ANY RELATED CONSTRUCTION. IF UNABLE TO REACH THE MINIMUM TIP ELEVATION, THE ADEQUACY OF THE SEAWALL PANEL DESIGN WILL REQUIRE RE-EVALUATION BY THE CITY'S ENGINEER.
8. COVER: CONCRETE COVER SHOWN IN THE PLANS DOES NOT INCLUDE REINFORCEMENT PLACEMENT AND FABRICATION TOLERANCES, UNLESS SHOWN AS "MINIMUM COVER". THE FOLLOWING MINIMUM CONCRETE COVER SHOULD BE PROVIDED:

PRECAST SEAWALL PANELS = 2 1/2"
 CAST IN PLACE SEAWALL CAP = 2 1/2" FOR EXTERNAL SURFACES
9. APPLIED FINISH: A SMOOTH TROWEL FINISH SHALL BE APPLIED TO THE WATER SIDE FACE OF THE CONCRETE SEAWALL PANEL. A BROOM FINISH SHALL BE APPLIED TO THE SURFACES OF THE SEAWALL CAP IN ACCORDANCE WITH SECTION 400 OF THE FDOT SPECIFICATIONS.
10. THE CONTRACTOR SHALL MAINTAIN THE INTEGRITY OF THE SEAWALL PANELS DURING INSTALLATION UNTIL FILL IS PLACED TO FINAL GRADE. FILL SHALL BE PLACED IN AREAS AWAY FROM THE WALL PRIOR TO PLACING AGAINST THE SEAWALL PANELS.
11. FLOATING TURBIDITY BARRIER AND/OR SILT FENCE SHALL BE REQUIRED DURING THE CONSTRUCTION OF THE SEAWALLS, CAP REPLACEMENT AND STAGING AREAS.
12. EXPANSION, LOAD TRANSFER, AND CONTRACTION JOINTS SHALL BE INSTALLED AS SHOWN IN THE WATERFRONT DEVELOPMENT STANDARDS.
13. SEAWALL PANELS ARE TONGUE AND GROOVE. ANY GAPS BETWEEN SEAWALL PANELS OF ONE INCH (1") TO THREE INCHES (3") SHALL BE PATCHED WITH MARINE GRADE HYDRAULIC CEMENT FROM THE BOTTOM OF THE CAP TO TWELVE INCHES (12") BELOW THE MUD LINE ON BOTH SIDES OF THE WALL, LANDSIDE AND WATERSIDE. ANY GAPS BETWEEN SEAWALL PANELS THAT ARE THREE INCHES (3") TO TWELVE INCHES (12") SHALL REQUIRE A BOX POUR FROM THE TOP OF SEAWALL PANEL TO TWELVE INCHES (12") BELOW THE MUD LINE WITH REINFORCED STEEL.

WHEN CONNECTING A NEW SEAWALL PANEL TO AN EXISTING SEAWALL PANEL, AND THE CONTRACTOR IS UNABLE TO UTILIZE THE TONGUE AND GROOVE, THE CONTRACTOR SHALL POUR A CONCRETE BOX FROM THE TOP OF SEAWALL PANEL TO TWELVE INCHES (12") BELOW THE MUD LINE. THE CONTRACTOR MUST INSTALL A REBAR CAGE AND CONNECT IT TO THE CAP REBAR CAGE. CONCRETE MUST BE 5500 PSI MARINE GRADE READY MIX CONCRETE FOR ALL BOX POURS. ALL WOOD FORMS SHALL BE REMOVED PRIOR TO FINAL INSPECTION. MAXIMUM ACCEPTABLE GAP BETWEEN EXISTING AND REPLACED SEAWALL PANELS IS TWELVE INCHES (12").
14. SWALE RESTORATION: REGRADE ROADSIDE SWALE TO CITY SPECIFICATIONS AND SOD ENTIRE LIMITS OF DISTURBED AREAS. INCLUDES REPLACEMENT LOCATIONS AND STAGING SITES.
15. SOD REQUIREMENTS AT VACANT LOTS AND EXISTING RESIDENCE:
 - A. VACANT LOTS - THE DISTURBED PORTIONS OF A VACANT LOT OR PROPERTY SHALL BE SODDED WITH ARGENTINE BAHIA. NO EXPOSED SOILS SHALL BE PERMITTED, INCLUDING ALL RIGHTS-OF-WAY AND DRAINAGE AREAS.
 - B. EXISTING RESIDENCE - ALL DISTURBED AREAS SHALL BE COMPLETELY SODDED WITH SOD THAT MATCHES EXISTING.

CITY OF PUNTA GORDA
 326 WEST MARION AVENUE
 PUNTA GORDA, FL. 33950
 (941) 575-5050

WATERFRONT
 DEVELOPMENT
 STANDARDS

STANDARD DETAIL

GENERAL NOTES

SHEET NO. WD-2

MAY 2022

REBAR SCHEDULE FOR 10' SEAWALL PANEL

QTY	LENGTH (FT)	SIZE	SHAPE	WEIGHT (LBS)
10	5.5	#4	STRAIGHT	36.74
2	9.75	#4	STRAIGHT	13.03
2	20.60	#5	HAIRPIN (12" DIA.)	42.97

REBAR SCHEDULE FOR 12.5' SEAWALL PANEL

QTY	LENGTH (FT)	SIZE	SHAPE	WEIGHT (LBS)
13	5.5	#4	STRAIGHT	47.76
5	12.25	#4	STRAIGHT	40.92
2	25.55	#5	HAIRPIN (7.5" DIA.)	53.30

REBAR SCHEDULE FOR 14' SEAWALL PANEL

QTY	LENGTH (FT)	SIZE	SHAPE	WEIGHT (LBS)
14	5.5	#4	STRAIGHT	51.44
8	13.67	#4	STRAIGHT	73.05
2	28.31	#5	HAIRPIN (5.75" DIA.)	59.05

REBAR SCHEDULE

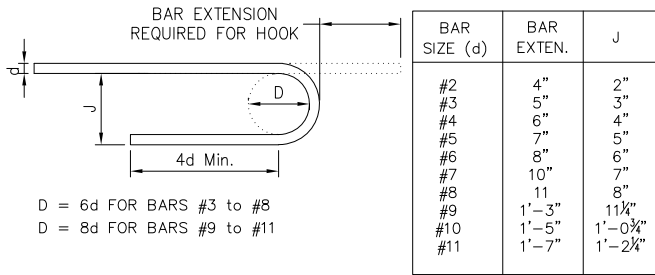

RECOMMENDED SIZES - 180° HOOK

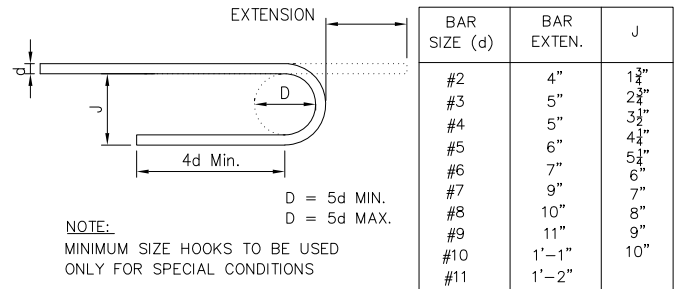

MINIMUM SIZES - 180° HOOK

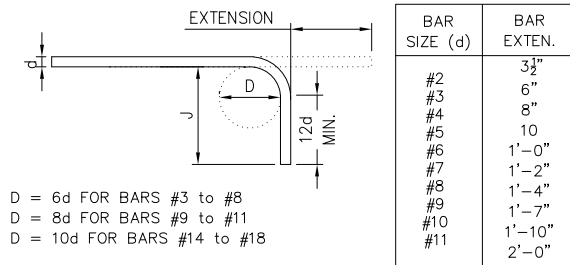

RECOMMENDED MINIMUM SIZES - 90° HOOK

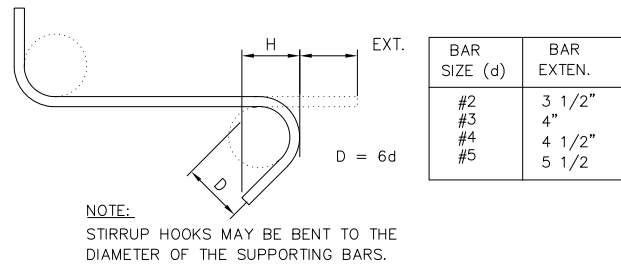

RECOMMENDED SIZES - 135° HOOK

STANDARD HOOK DETAILS

CITY OF PUNTA GORDA
326 WEST MARION AVENUE
PUNTA GORDA, FL. 33950
(941) 575-5050

WATERFRONT
DEVELOPMENT
STANDARDS

STANDARD DETAIL

REBAR DETAILS

SHEET NO. WD-3

AUGUST 2019

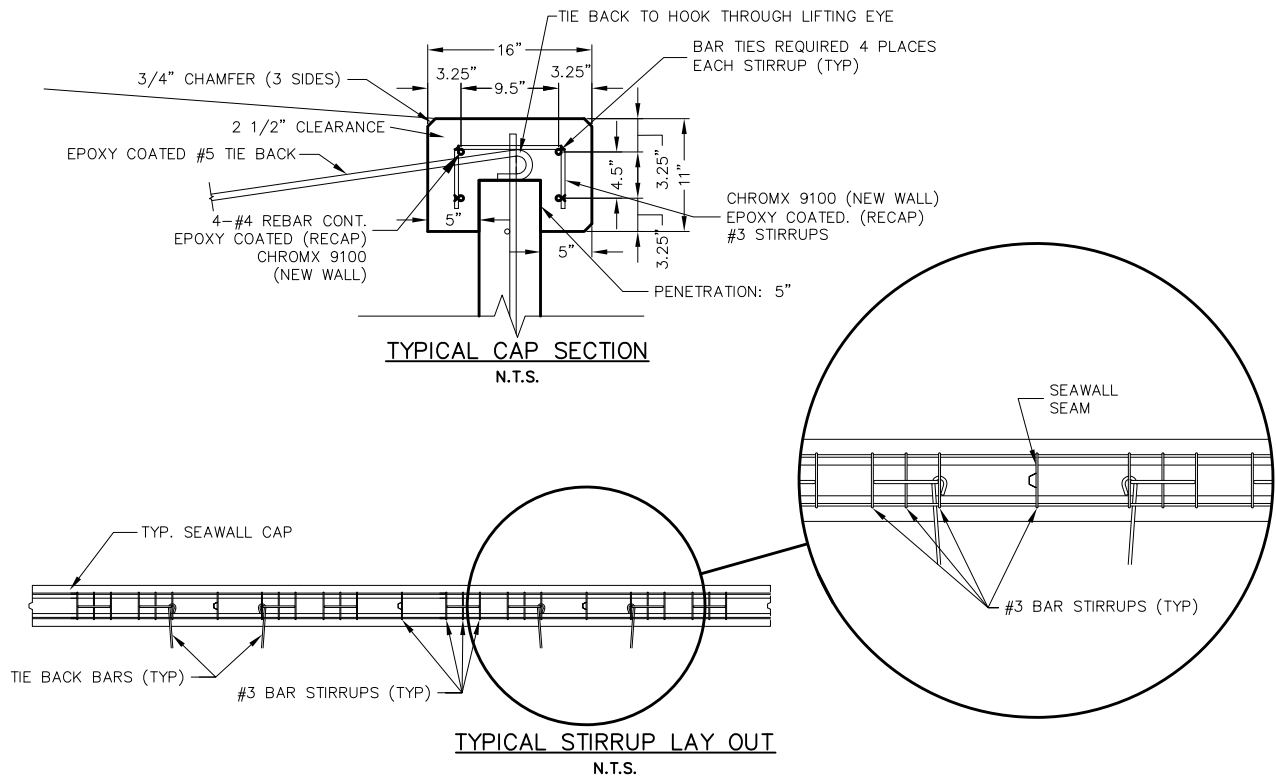

NOTE:
 MAXIMUM 1 FOOT SPACING. 1 STIRRUP OVER EACH SEAM; 1 STIRRUP OVER EACH LIFTING EYE; 1 STIRRUP ON THE RIGHT AND 1 STIRRUP ON THE LEFT OF THE LIFTING EYE. 15 STIRRUPS MINIMUM IN A 12 FOOT SECTION (2 SEAWALL PANELS)

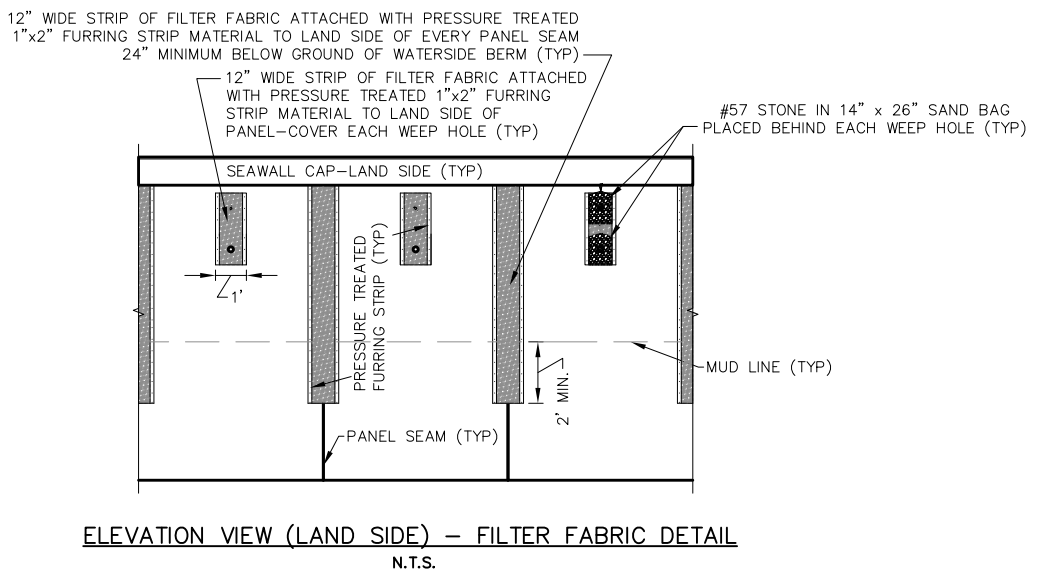

CITY OF PUNTA GORDA
 326 WEST MARION AVENUE
 PUNTA GORDA, FL. 33950
 (941) 575-5050

WATERFRONT
 DEVELOPMENT
 STANDARDS

STANDARD DETAIL

SEAWALL CAP AND
 FILTER FABRIC DETAILS

SHEET NO. WD-4

AUGUST 2019

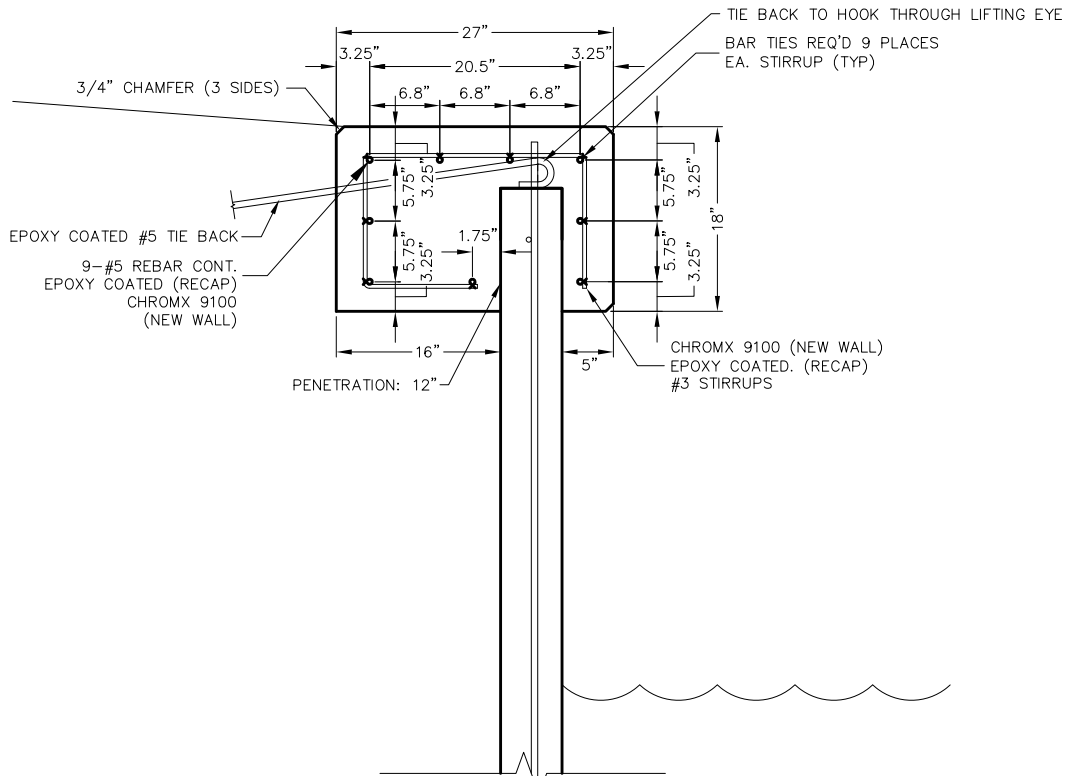

TYPICAL CAP SECTION
N.T.S.

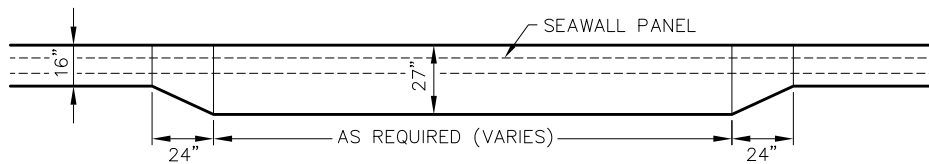

SEAWALL CAP TRANSITION PLAN VIEW
N.T.S.

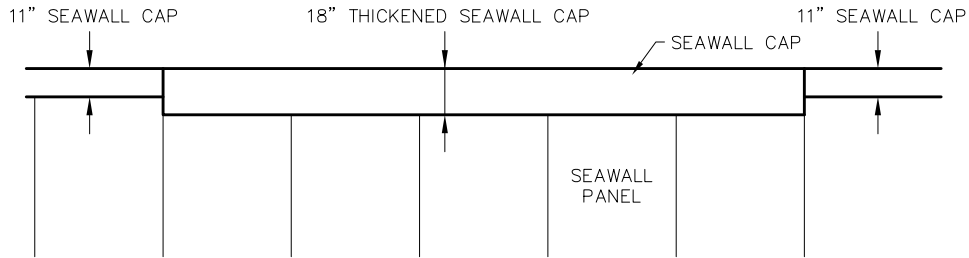

SEAWALL CAP TRANSITION ELEVATION VIEW FROM WATER
N.T.S.

CITY OF PUNTA GORDA

326 WEST MARION AVENUE
PUNTA GORDA, FL. 33950
(941) 575-5050

WATERFRONT
DEVELOPMENT
STANDARDS

STANDARD DETAIL

THICKENED SEAWALL CAP
(SPECIAL USE)

SHEET NO. WD-5

AUGUST 2019

NOTE:
 TO BE UTILIZED WITH NEW SEAWALL AND CAP CONSTRUCTION; AND ALL CAP REPLACEMENTS. EXPANSION JOINTS SHALL BE PLACED APPROXIMATELY 80-85 FEET ON CENTER NEAR THE PROPERTY LINE(S). CONTRACTION JOINTS TO BE PLACED MIDWAY BETWEEN EXPANSION JOINTS.

ALL EXPANSION JOINTS TO BE PLACED AT/OVER THE SEAWALL PANEL JOINT.

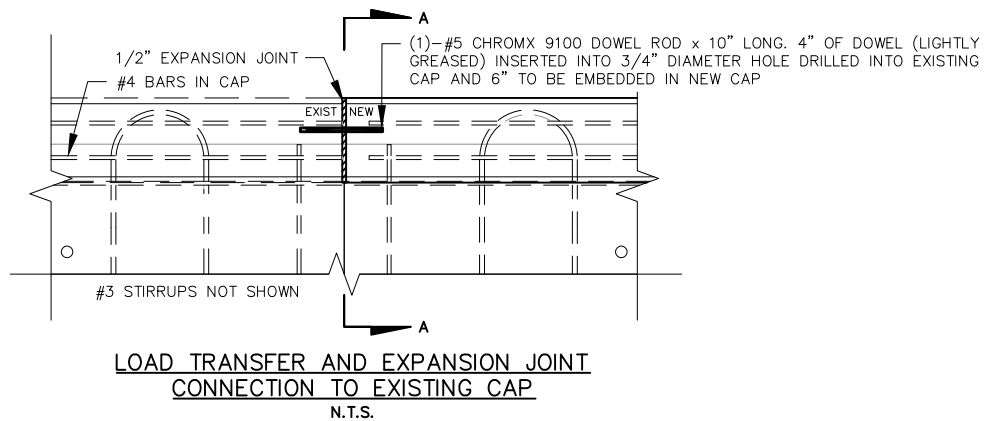
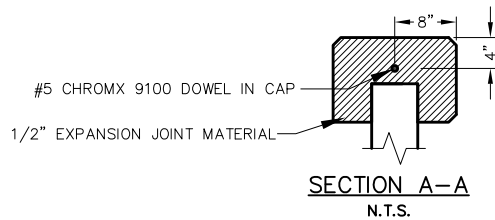
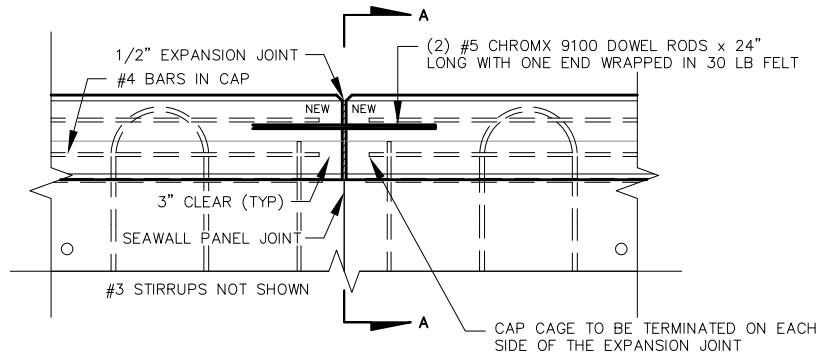
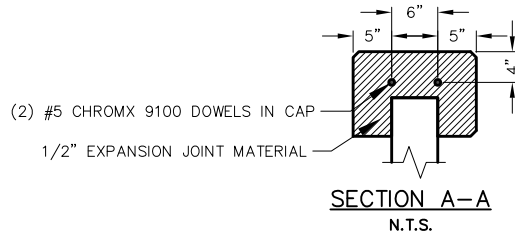

CITY OF PUNTA GORDA
 326 WEST MARION AVENUE
 PUNTA GORDA, FL. 33950
 (941) 575-5050

WATERFRONT
 DEVELOPMENT
 STANDARDS

STANDARD DETAIL

EXPANSION JOINT AND
 LOAD TRANSFER DETAILS

SHEET NO. WD-6

AUGUST 2019

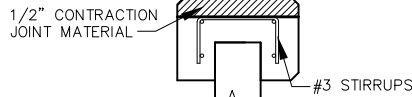

SECTION A-A
N.T.S.

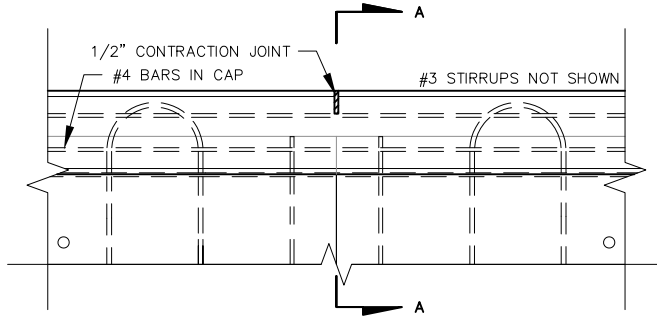

CONTRACTION JOINT DETAIL
N.T.S.

NOTE:
EXPANSION JOINTS SHALL BE PLACED APPROX 80-85 FEET O.C. NEAR THE PROPERTY LINE(S). CONTRACTION JOINTS TO BE PLACED MIDWAY BETWEEN EXPANSION JOINTS.

ALL EXPANSION AND CONTRACTION JOINTS TO BE PLACED AT/OVER THE SEAWALL PANEL JOINT

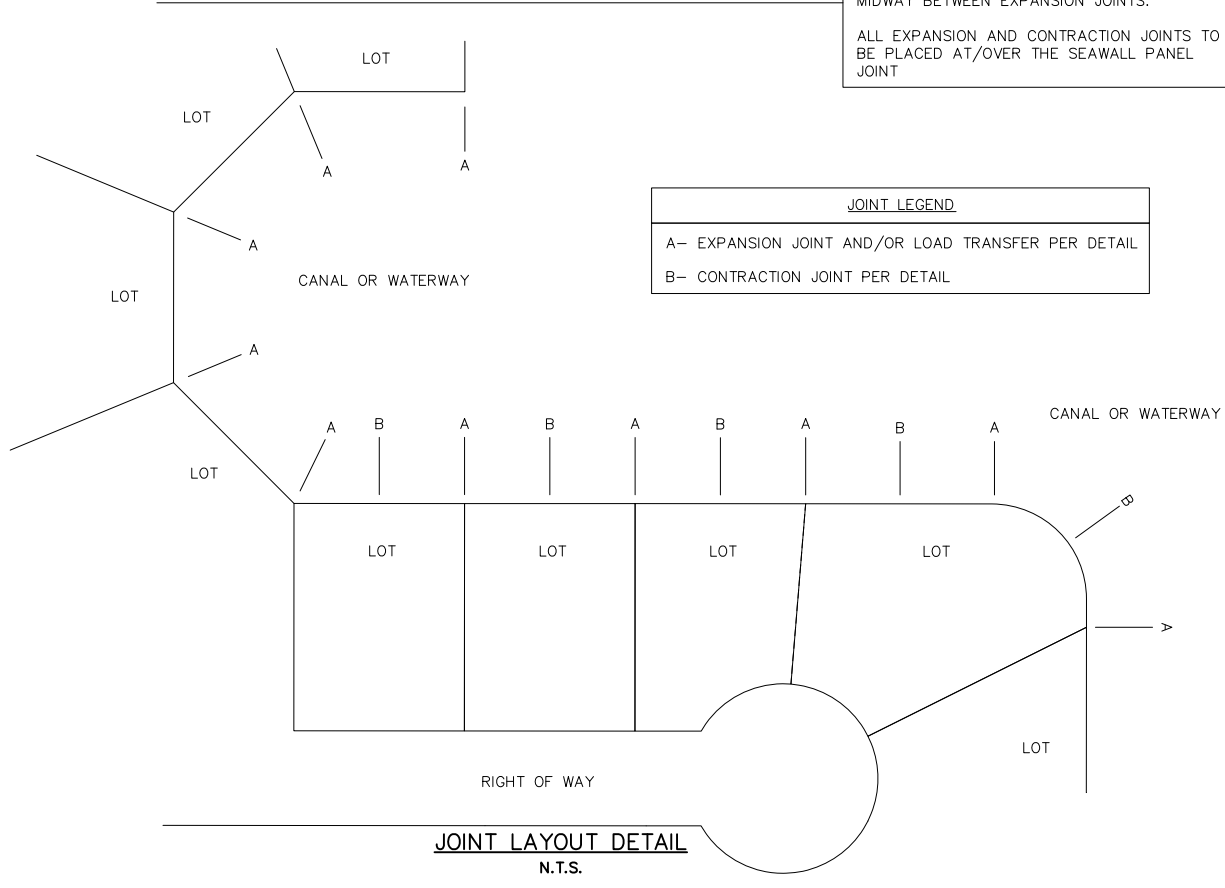

JOINT LEGEND	
A-	EXPANSION JOINT AND/OR LOAD TRANSFER PER DETAIL
B-	CONTRACTION JOINT PER DETAIL

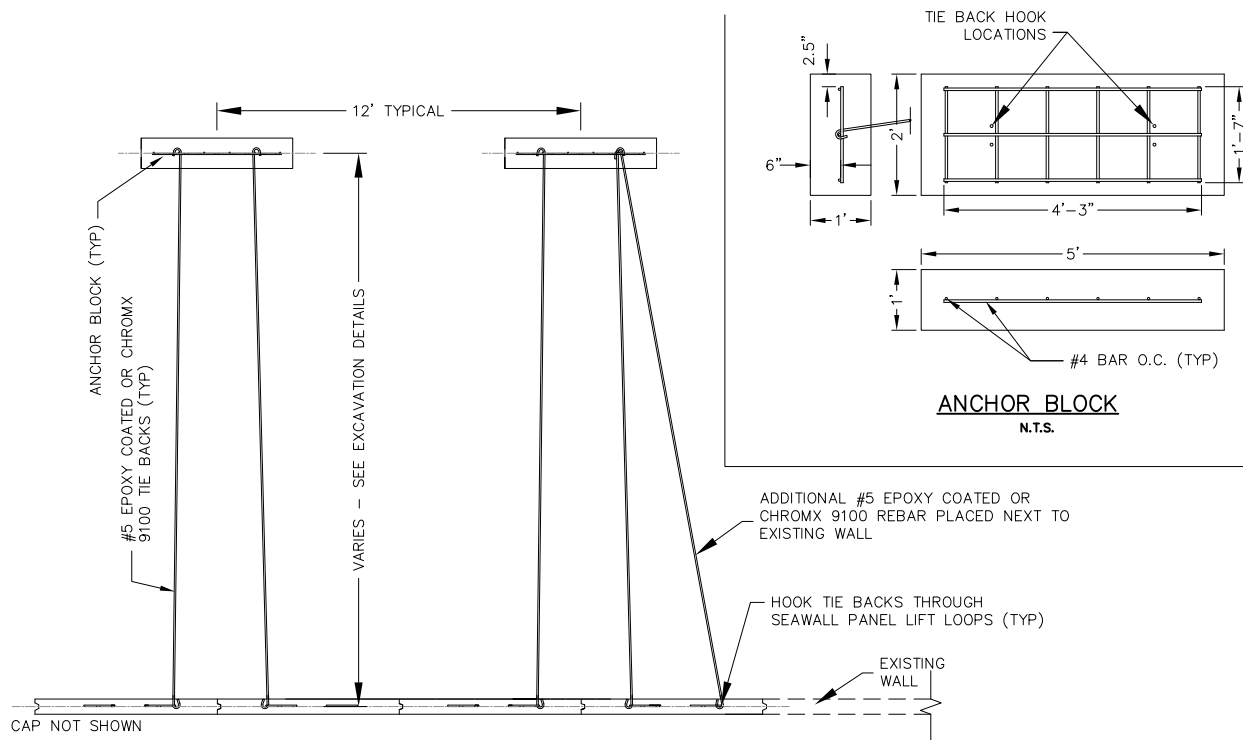

TYPICAL TIE BACK AND NEW ANCHOR BLOCK

N.T.S.

USE OF EXISTING ANCHOR BLOCKS AND THE LOCATION OF NEW ANCHOR BLOCKS SHALL BE APPROVED BY THE CITY.

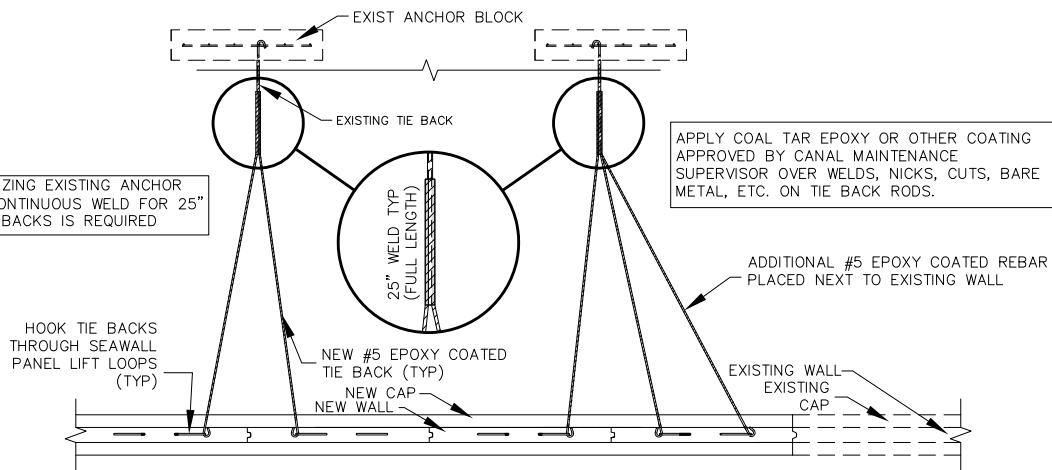

TIE BACK BAR DETAIL FOR UTILIZING EXISTING ANCHOR BLOCK

N.T.S.

CITY OF PUNTA GORDA

326 WEST MARION AVENUE
PUNTA GORDA, FL. 33950
(941) 575-5050

WATERFRONT
DEVELOPMENT
STANDARDS

STANDARD DETAIL

ANCHOR/TIE BACK DETAILS

SHEET NO. WD-8

AUGUST 2019

NOTE:
PLACE ROCK ANCHOR TIE BACK @ 12' O.C. USE STANDARD TIE BACK RODS WITH HOOKS

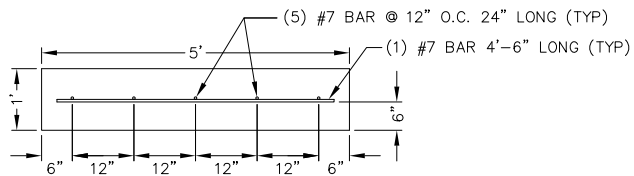

ANCHOR BLOCK – PLAN VIEW
N.T.S.

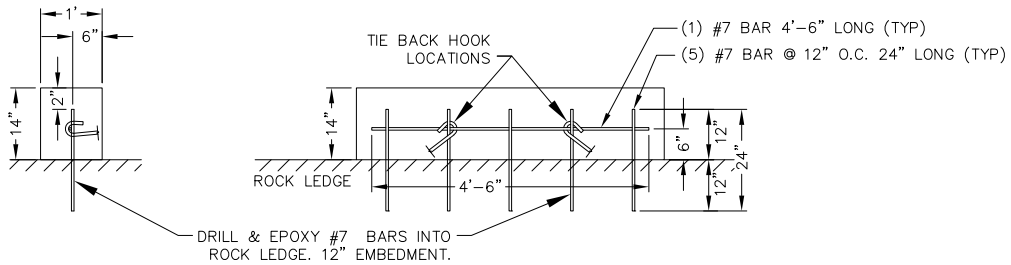

**ANCHOR BLOCK
SIDE ELEVATION VIEW**
N.T.S.

**ANCHOR BLOCK
FRONT ELEVATION VIEW**
N.T.S.

STEEL SCHEDULE	
1 EACH	- #7 BAR @ 4'-6"
5 EACH	- #7 BAR @ 2'-0"

CONST DIMENSION CHART			
A- PANEL LENGTH	10'-0"	12'-6"	14'-0"
B- MIN. PENETRATION	4'-0"	6'-0"	6'-6"
C- DIST TO ANCHOR	18'-3"	21'-0"	24'-3"
D- MAX. EXPOSURE	6'-6"	7'-0"	8'-0"

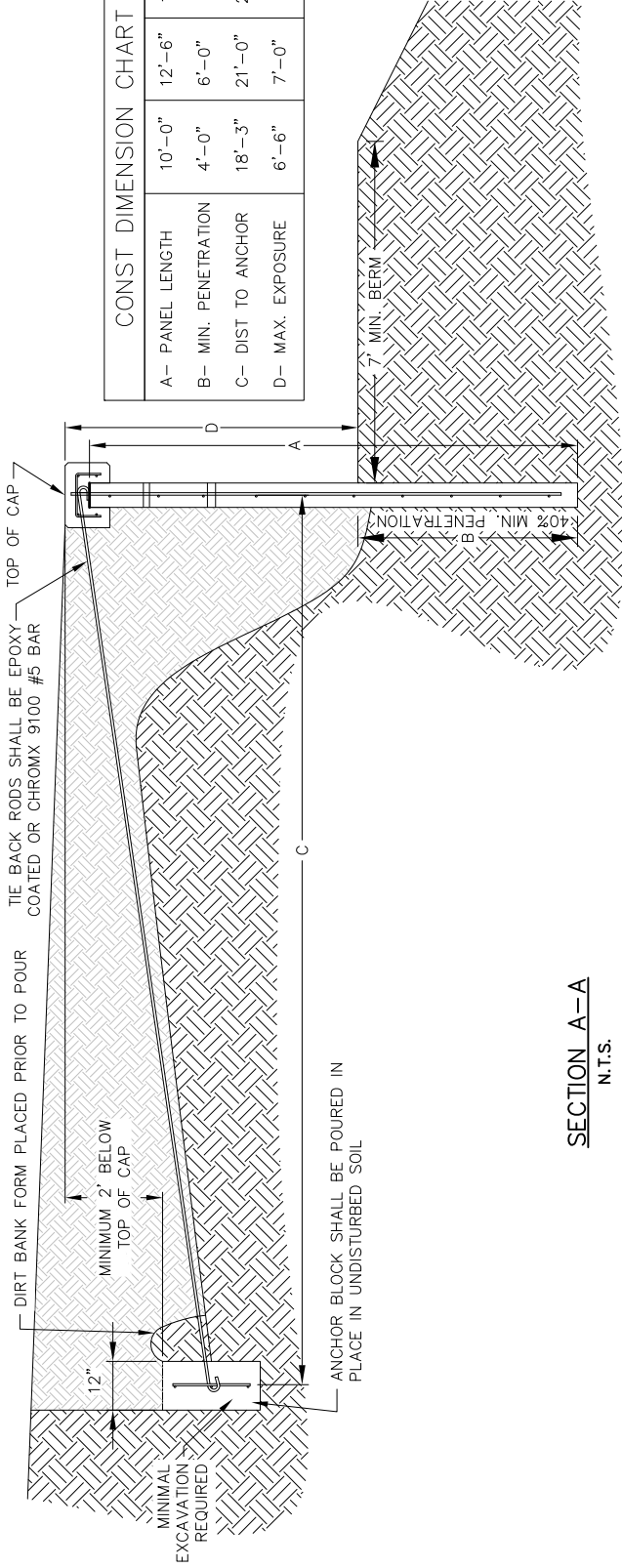

SECTION A-A
N.T.S.

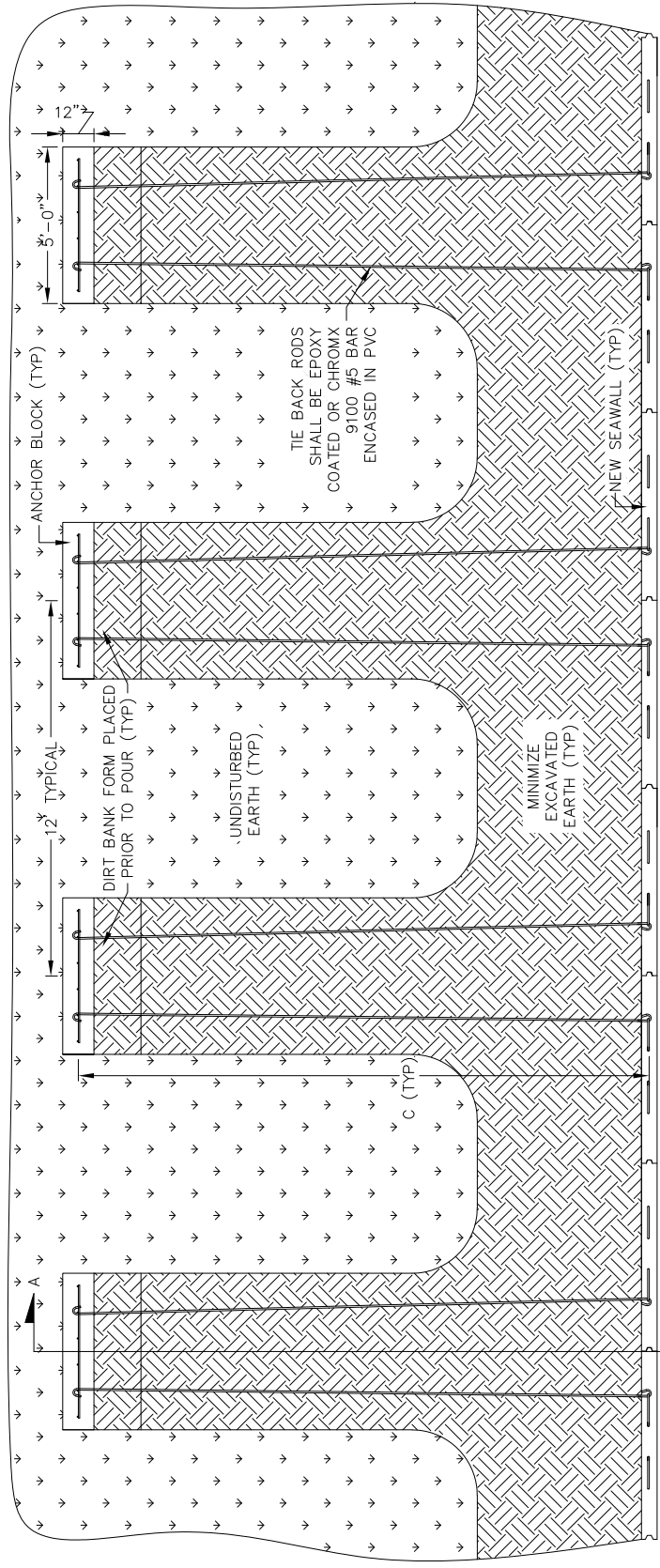

TYPICAL EXCAVATION PLAN VIEW
N.T.S.

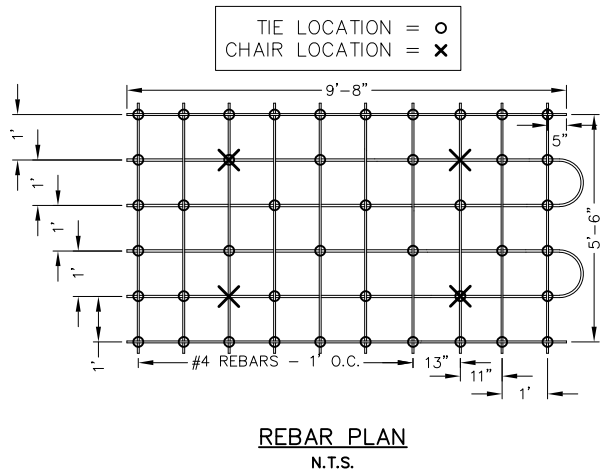

PANELS MUST BE STAMPED AS SHOWN USING A COMMERCIALY AVAILABLE CONCRETE STAMP SYSTEM. NUMBERS ARE 2" TALL x 1/2" DEEP FONT IS ARIAL BOLD. DISPLAY = 2 DIGITS FOR DAY, 2 DIGITS FOR MONTH 4 DIGITS FOR YEAR, WITH DASH BETWEEN DATE. DATE STAMP TO BE ON WATERSIDE OF SEAWALL PANEL.

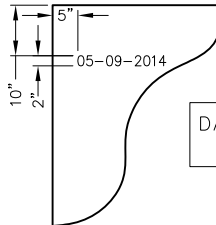

DATE STAMP DETAILS TYPICAL FOR ALL SEAWALL PANEL LENGTHS

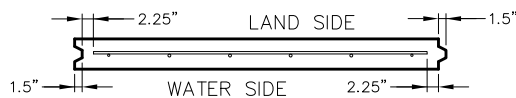

REBAR MAT SHALL TOUCH THE HEAD BOARD OF THE FORM PRIOR/DURING CONCRETE POUR

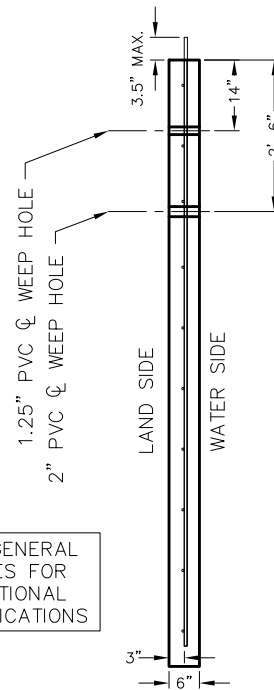
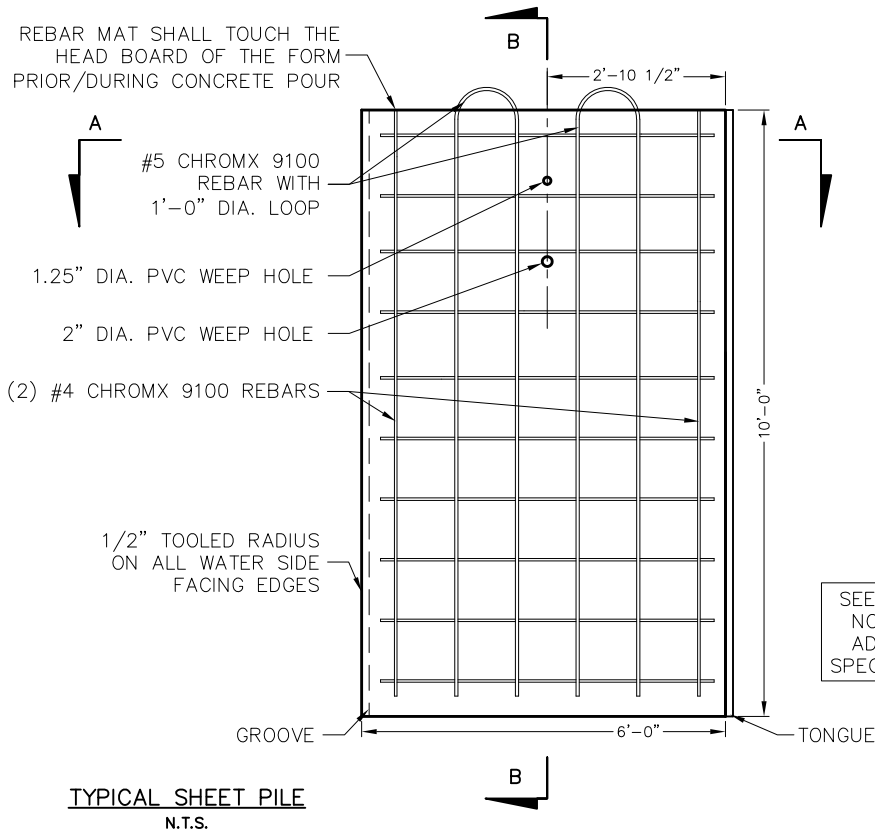

SEE GENERAL NOTES FOR ADDITIONAL SPECIFICATIONS

CITY OF PUNTA GORDA

326 WEST MARION AVENUE
PUNTA GORDA, FL. 33950
(941) 575-5050

WATERFRONT
DEVELOPMENT
STANDARDS

STANDARD DETAIL

10'-0" PRECAST
SEAWALL PANEL DETAILS

SHEET NO. WD-11

AUGUST 2019

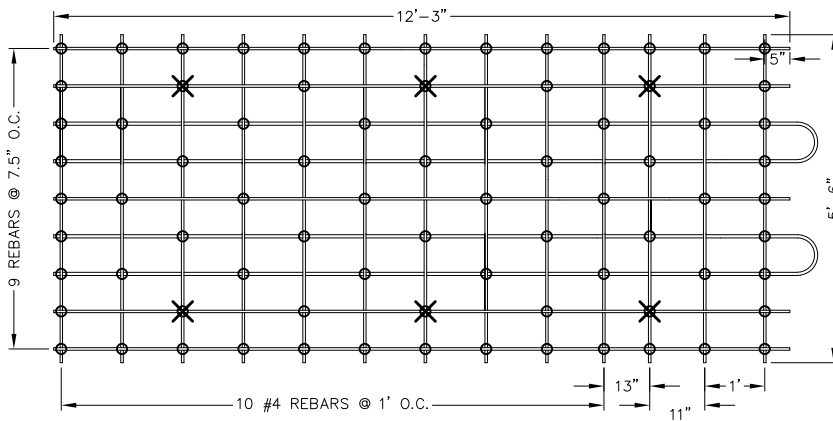

DATE STAMP DETAILS TYPICAL FOR ALL SEAWALL PANEL LENGTHS SEE 10'-0" PRECAST SEAWALL PANEL DETAIL

TIE LOCATION = ○
CHAIR LOCATION = ×

REBAR PLAN
N.T.S.

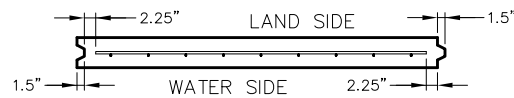

SECTION A-A
N.T.S.

REBAR MAT SHALL TOUCH THE HEAD BOARD OF THE FORM PRIOR/DURING CONCRETE POUR

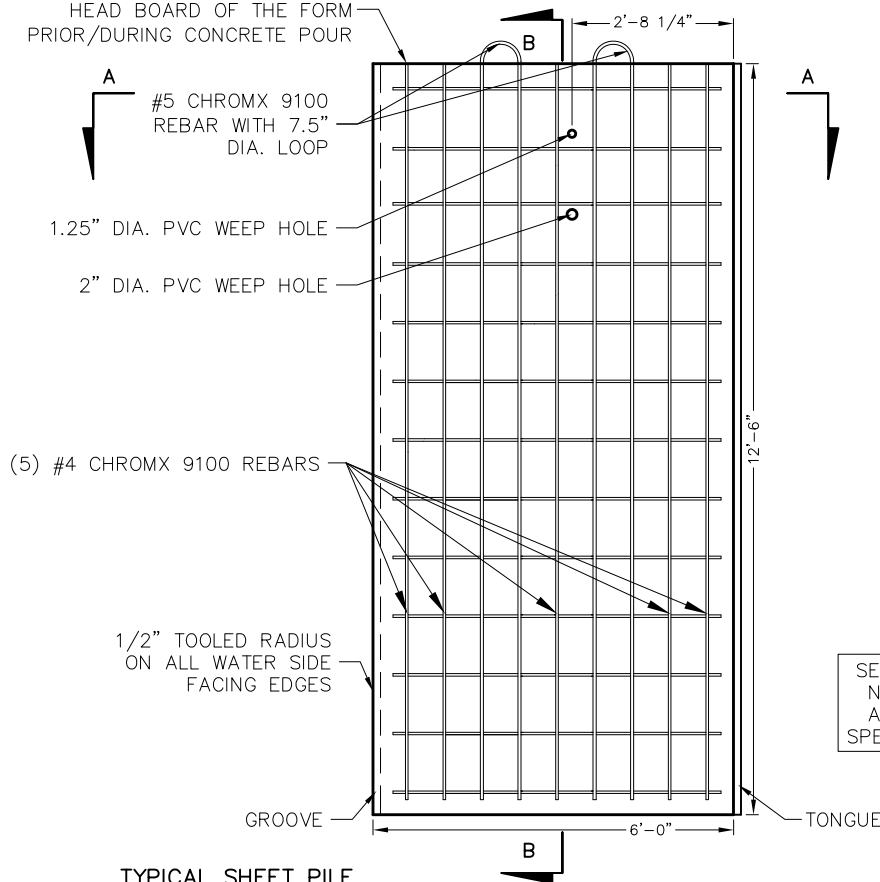

TYPICAL SHEET PILE
N.T.S.

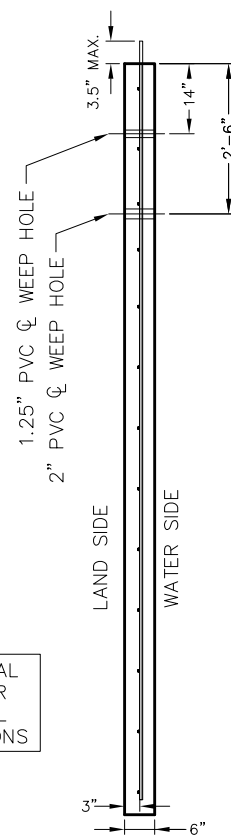

SECTION B-B
N.T.S.

SEE GENERAL NOTES FOR ADDITIONAL SPECIFICATIONS

CITY OF PUNTA GORDA

326 WEST MARION AVENUE
PUNTA GORDA, FL. 33950
(941) 575-5050

WATERFRONT
DEVELOPMENT
STANDARDS

STANDARD DETAIL

12'-6" PRECAST
SEAWALL PANEL DETAILS

SHEET NO. WD-12

AUGUST 2019

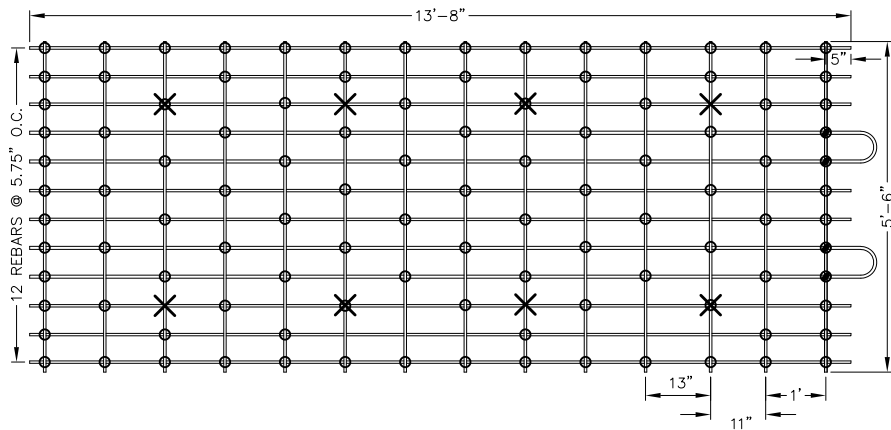

DATE STAMP DETAILS TYPICAL FOR ALL SEAWALL PANEL LENGTHS SEE 10'-0" PRECAST SEAWALL PANEL DETAIL

TIE LOCATION = ○
CHAIR LOCATION = X

REBAR PLAN
N.T.S.

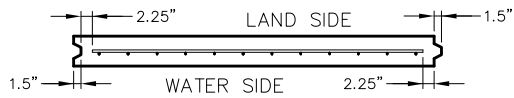

SECTION A-A
N.T.S.

REBAR MAT SHALL TOUCH THE HEAD BOARD OF THE FORM PRIOR/DURING CONCRETE POUR

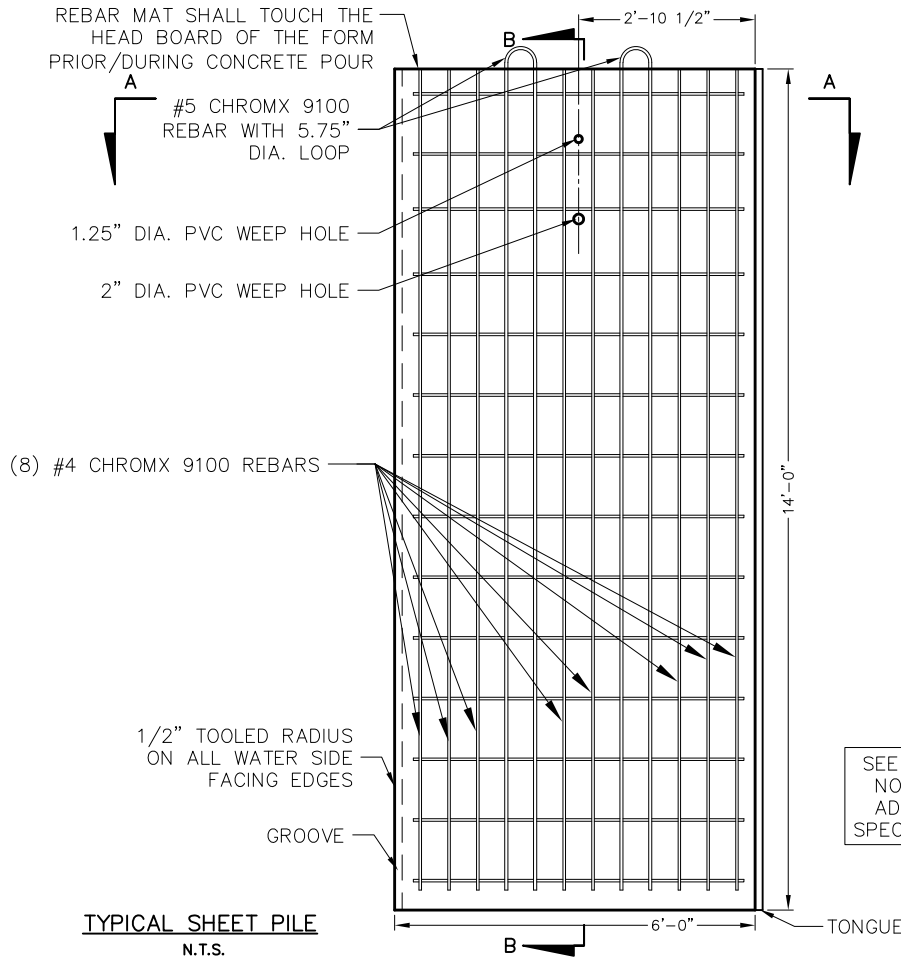

TYPICAL SHEET PILE
N.T.S.

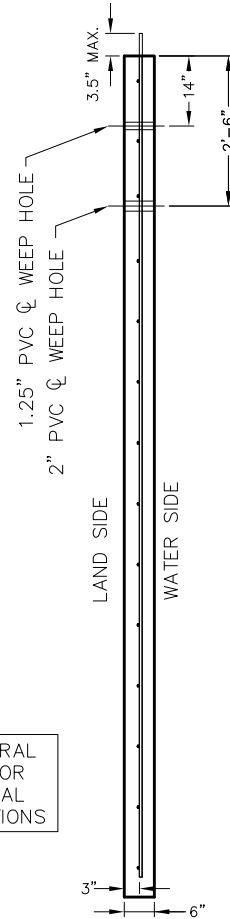

SECTION B-B
N.T.S.

SEE GENERAL NOTES FOR ADDITIONAL SPECIFICATIONS

CITY OF PUNTA GORDA

326 WEST MARION AVENUE
PUNTA GORDA, FL. 33950
(941) 575-5050

WATERFRONT
DEVELOPMENT
STANDARDS

STANDARD DETAIL

14'-0" PRECAST
SEAWALL PANEL DETAILS

SHEET NO. WD-13

AUGUST 2019

REBAR PLAN
N.T.S.

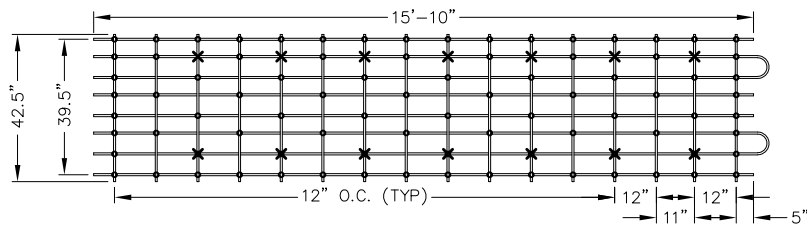

DATE STAMP DETAILS TYPICAL FOR ALL SEAWALL PANEL LENGTHS SEE 10'-0" PRECAST SEAWALL PANEL DETAIL

TIE LOCATION = ○
CHAIR LOCATION = X

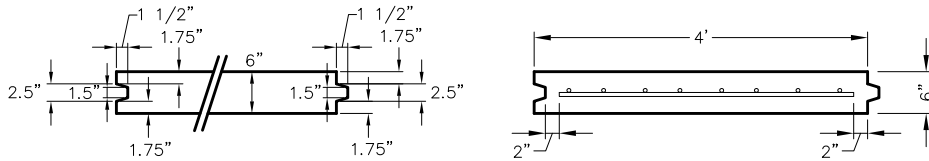

SECTION A-A
N.T.S.

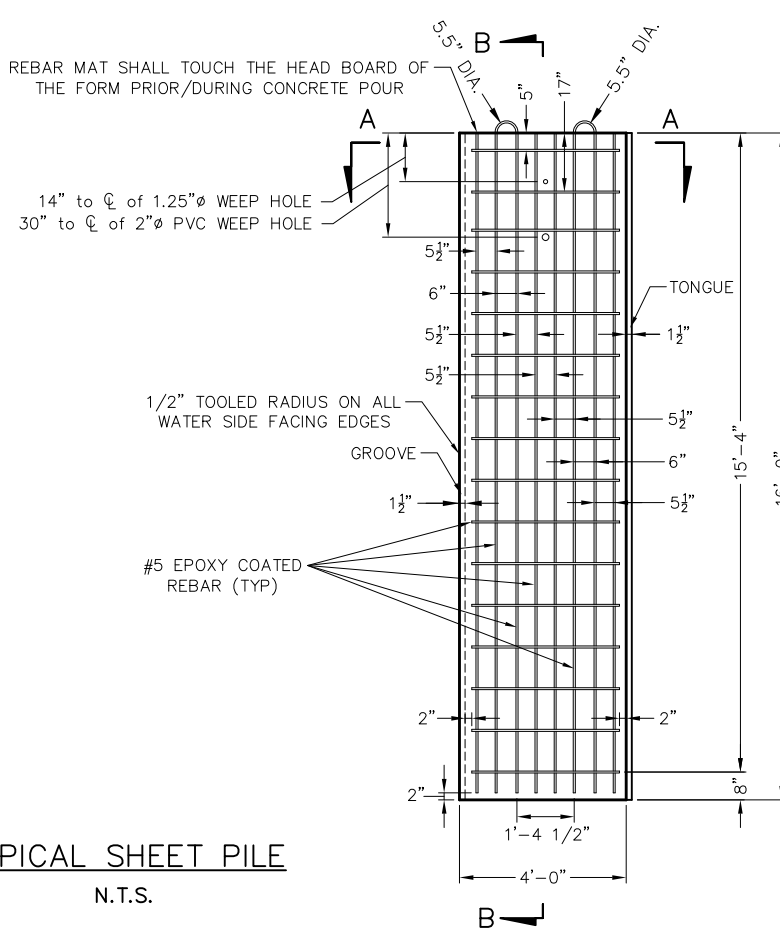

TYPICAL SHEET PILE
N.T.S.

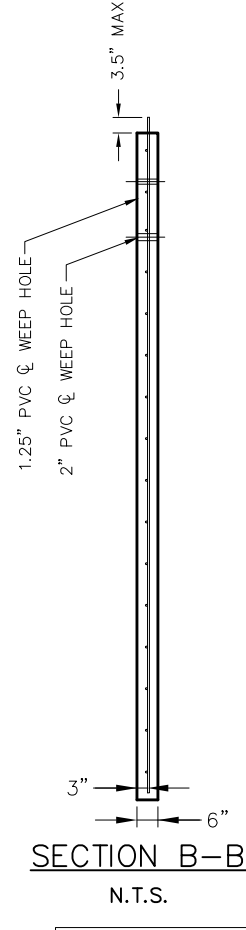

SECTION B-B
N.T.S.

SEE GENERAL NOTES FOR ADDITIONAL SPECIFICATIONS

CITY OF PUNTA GORDA
326 WEST MARION AVENUE
PUNTA GORDA, FL. 33950
(941) 575-5050

WATERFRONT
DEVELOPMENT
STANDARDS

STANDARD DETAIL	
16'-0" PRECAST SEAWALL PANEL DETAILS	
SHEET NO. WD-14	AUGUST 2019

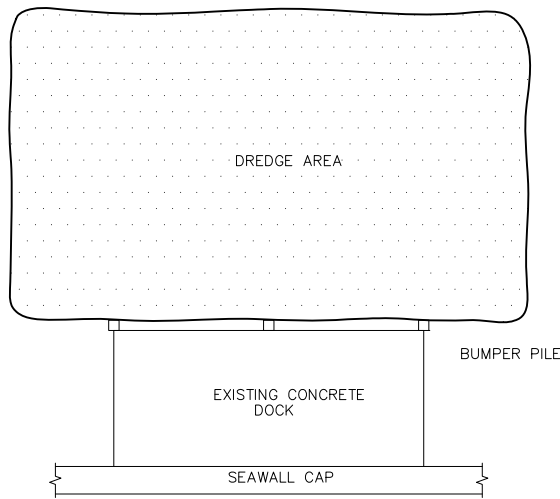
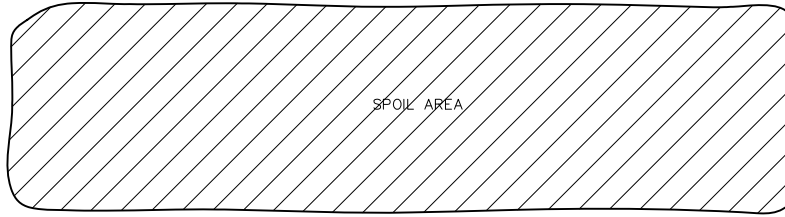

TYPICAL DREDGING DETAIL-PLAN VIEW
N.T.S.

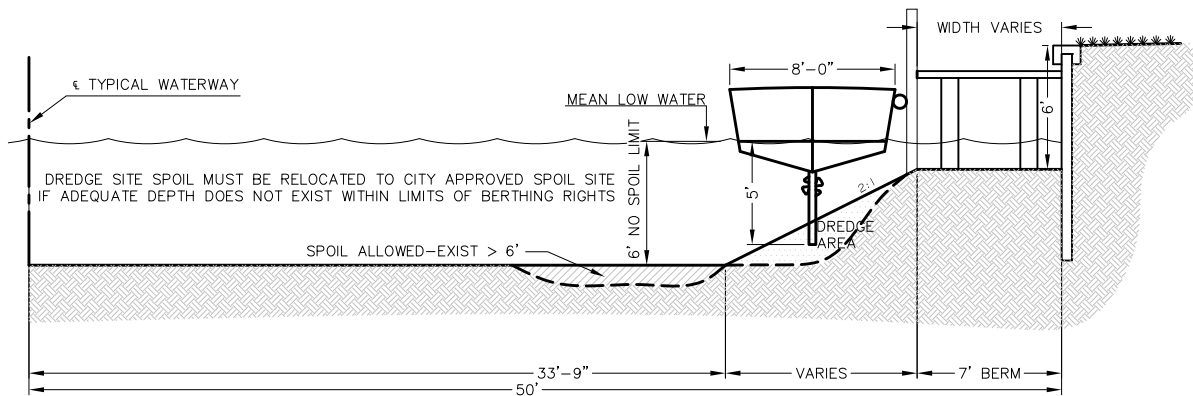

TYPICAL DREDGING DETAIL-ELEVATION VIEW
N.T.S.

CITY OF PUNTA GORDA
326 WEST MARION AVENUE
PUNTA GORDA, FL. 33950
(941) 575-5050

WATERFRONT
DEVELOPMENT
STANDARDS

STANDARD DETAIL

STANDARD DOCKSIDE
DREDGING DETAIL

SHEET NO. WD-15

AUGUST 2019

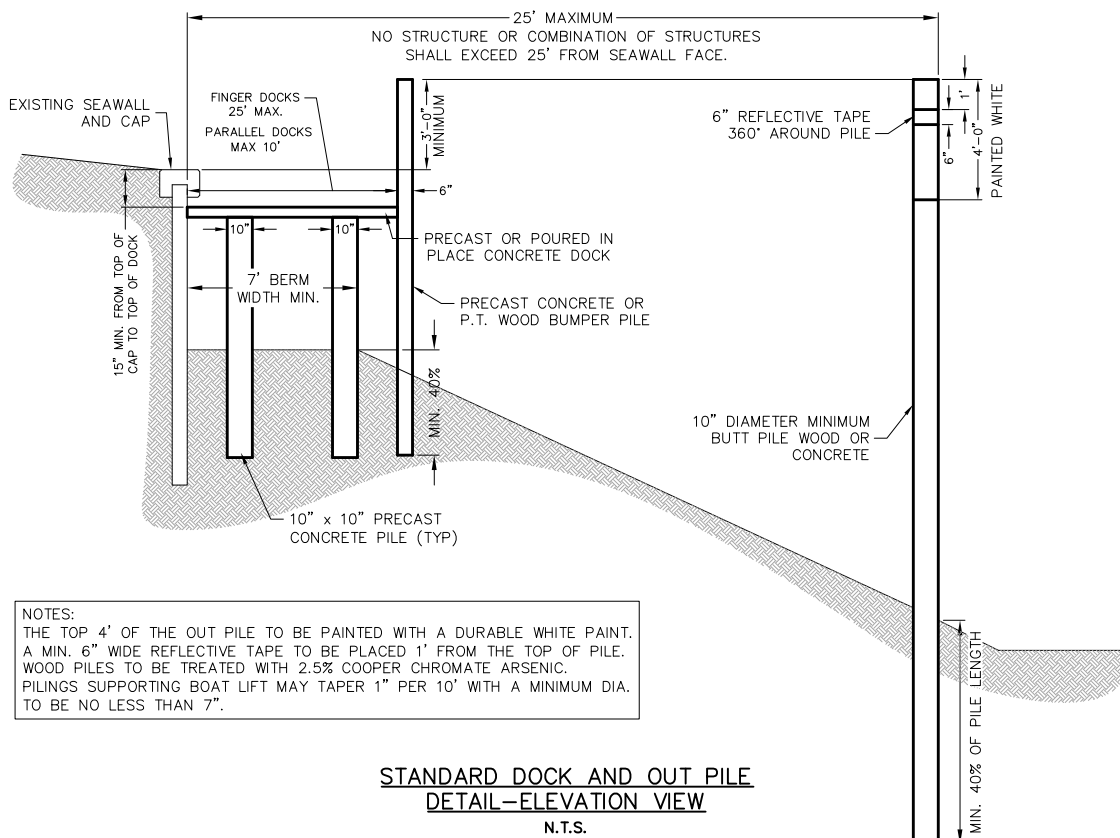
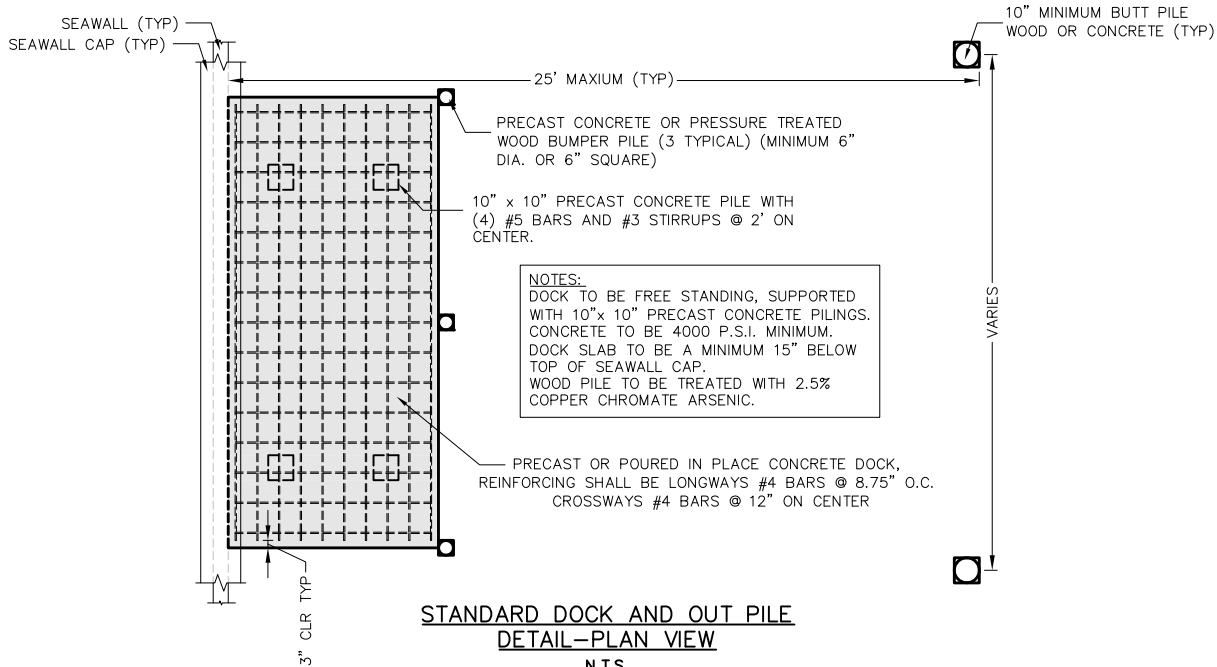

CITY OF PUNTA GORDA

326 WEST MARION AVENUE
PUNTA GORDA, FL. 33950
(941) 575-5050

WATERFRONT
DEVELOPMENT
STANDARDS

STANDARD DETAIL

STANDARD CONCRETE DOCK
AND OUT PILE DETAIL

SHEET NO. WD-16

AUGUST 2019

NOTES:

THIS CROSS SECTION IS INTENDED TO SHOW THE ACCEPTED METHOD OF INSTALLING FILTER FABRIC. DO NOT USE THIS DRAWING TO CALCULATE MATERIAL QUANTITIES. THE SIZE OF THE ROCK RIP RAP SHALL BE 12" TO 24" . LONGITUDINAL LAPS ON FILTER CLOTH SHALL BE 18" MINIMUM.

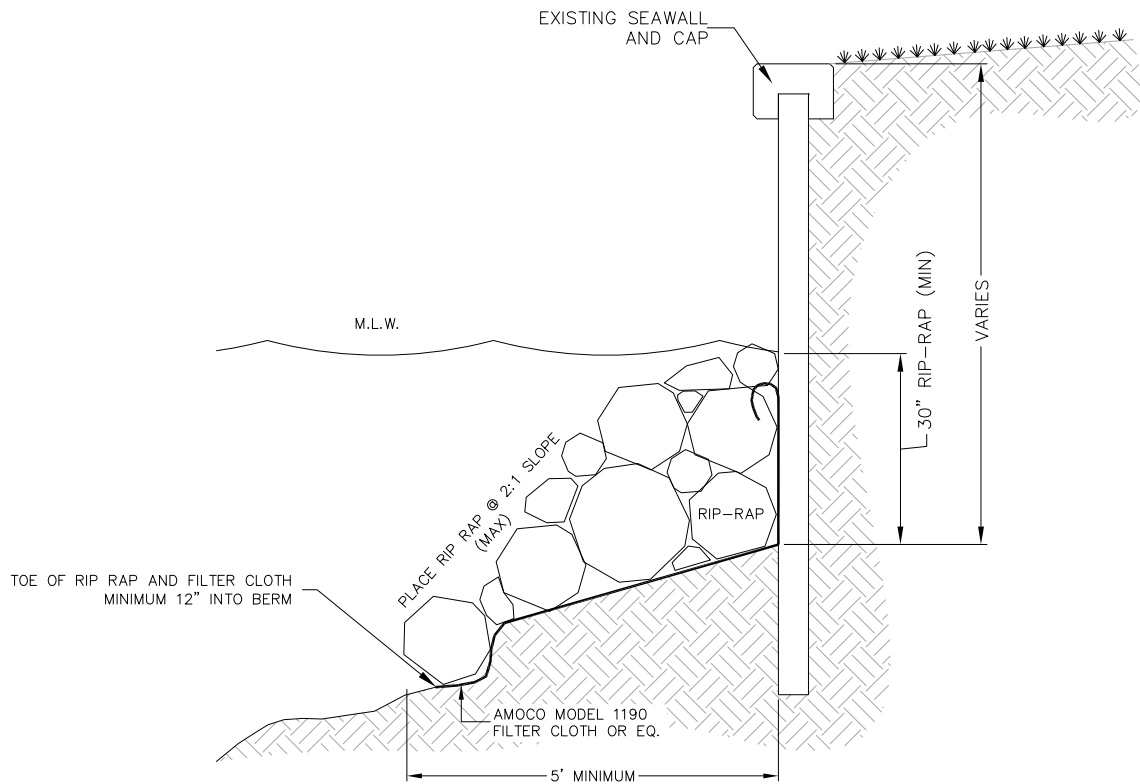

TYPICAL CROSS SECTION
N.T.S.

CITY OF PUNTA GORDA

326 WEST MARION AVENUE
PUNTA GORDA, FL. 33950
(941) 575-5050

WATERFRONT
DEVELOPMENT
STANDARDS

STANDARD DETAIL

RIP-RAP
STABILIZATION DETAIL

SHEET NO. WD-17

AUGUST 2019

NOTES:
 THIS CROSS SECTION IS INTENDED TO SHOW THE ACCEPTED METHOD OF INSTALLING FILTER FABRIC. DO NOT USE THIS DRAWING TO CALCULATE MATERIAL QUANTITIES. THE SIZE OF THE ROCK RIP RAP SHALL BE 12" TO 24". LONGITUDINAL LAPS ON FILTER CLOTH SHALL BE 18" MINIMUM.

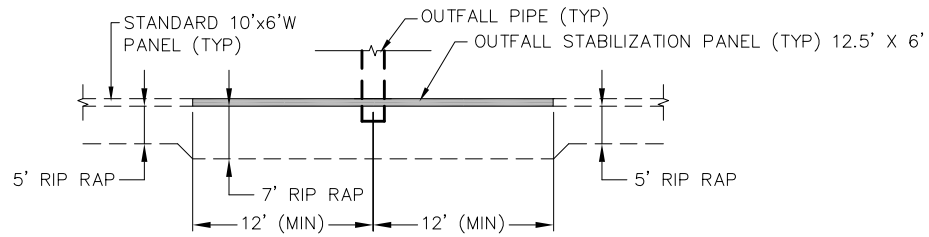

TOP VIEW SECTION

N.T.S.

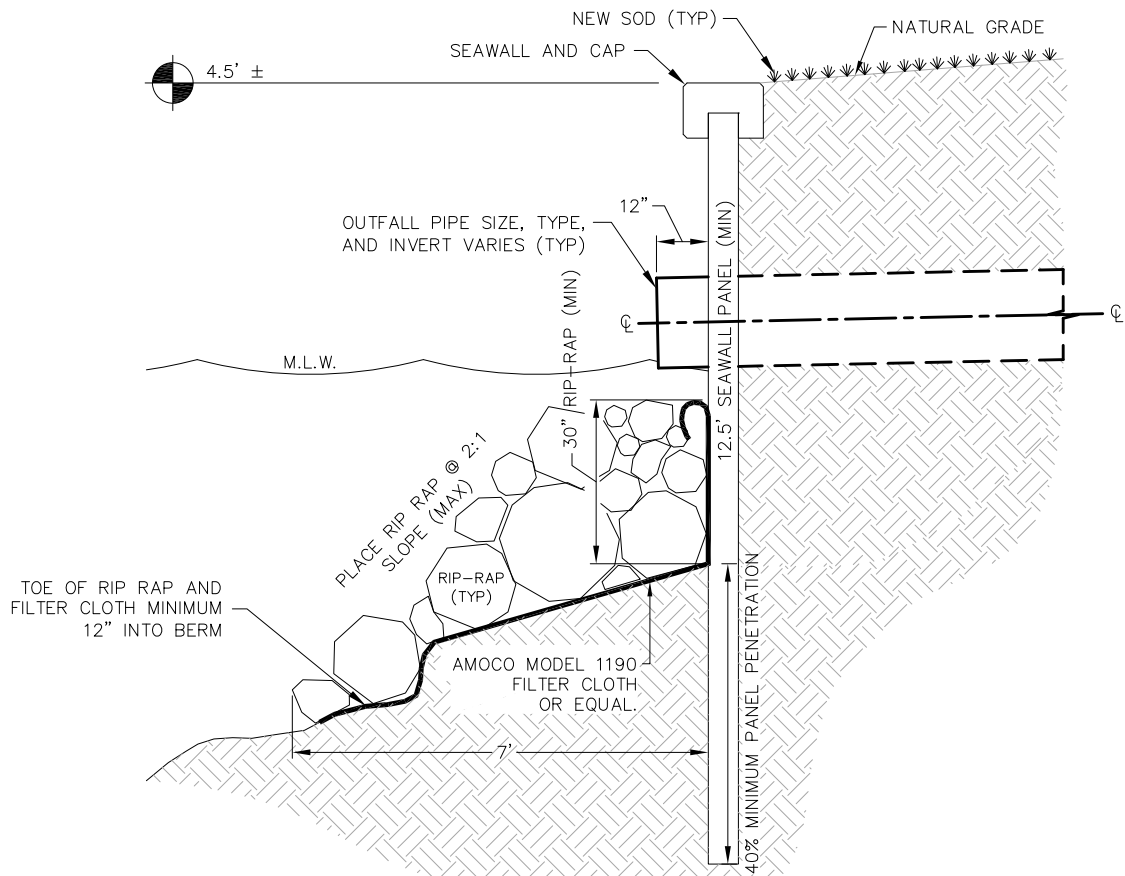

TYPICAL CROSS SECTION

N.T.S.

CITY OF PUNTA GORDA

326 WEST MARION AVENUE
 PUNTA GORDA, FL. 33950
 (941) 575-5050

WATERFRONT
 DEVELOPMENT
 STANDARDS

STANDARD DETAIL

OUTFALL STABILIZATION DETAIL

SHEET NO. WD-18

AUGUST 2019